

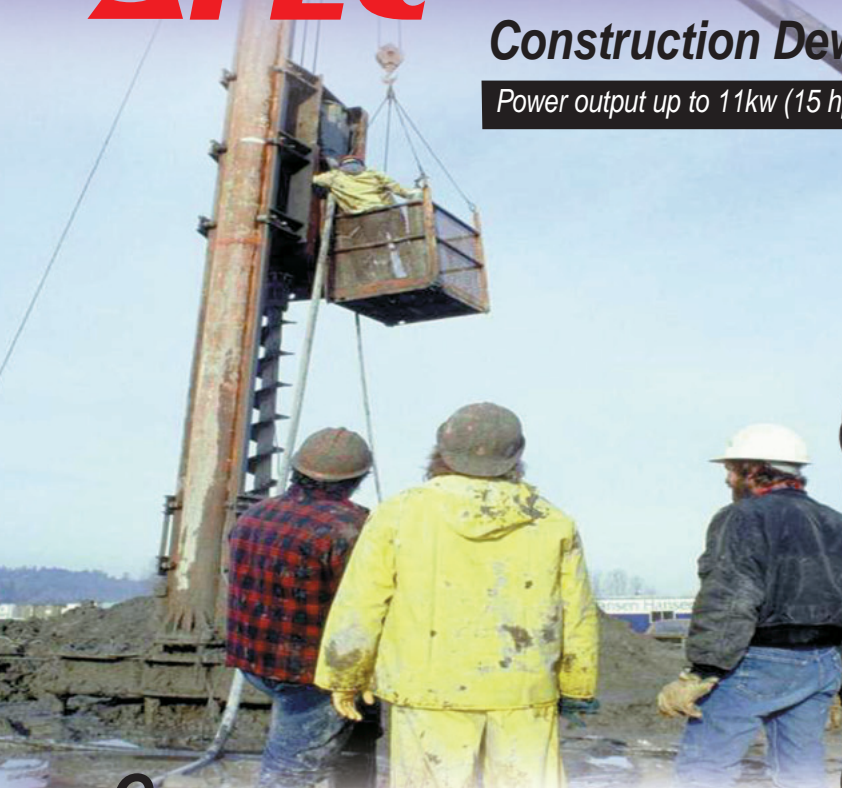

FS Series Construction Dewatering Pumps

Power output up to 11kw (15 hp). Head up to 50m (165 ft). Flow up to 2500 l/min (660 gpm)



Compact design, high performance and exceptional durability for handling abrasive liquid, widely used on general construction and civil engineering.

Pump Description:

Designed for continuous duty with stable operating performance to carry dirty or clean water, for drainage and irrigation purpose. It features an up-discharge and double-casing design and the motor is always cooled by the pumped liquid, which gives it a superior cooling effect and long-lasting running no need to be personally attended on site. The pump is constructed of:

- fine casting discharge outlet and top cover,
- rigid stainless steel outer case and strainer,
- quality stainless steel 410 motor shaft protected by sleeve against direct wear by the contact parts,
- double mechanical seals (lower silicon carbide V silicon carbide, upper carbon/ceramic) in oil chamber,
- dynamically balanced high chrome steel impeller,
- lubricated-for-life and maintenance free bearings to support shaft,
- and standard 10 meters (33 ft) power cord (or longer upon request).

Motor Features:

- Dry motor with thermal and over-current protector.
- Asynchronous 3 phase (single-phase is available for 1.5kw/2hp), 2 pole, 50Hz/2850rpm or 60Hz/3450rpm.
- Class F insulation, IP68 protection.
- Max. liquid temperature: 40° (104°F)

Applications

- Wastewater discharge for industries and municipalities.
- Deep well pumping, construction sites, and civil engineering projects incl.: subways, tunnels, dams, and etc.
- Utilities: telecommunications, power generation plants.

FS Series FS Series

Discharge: 50mm (2") or 80mm (3")
Power Output: 1.5kw (2hp) and 2.2kw (3hp)
Head: up to 27m (89ft)
Flow: up to 800 l/min (211 USgpm)



Performance Curve

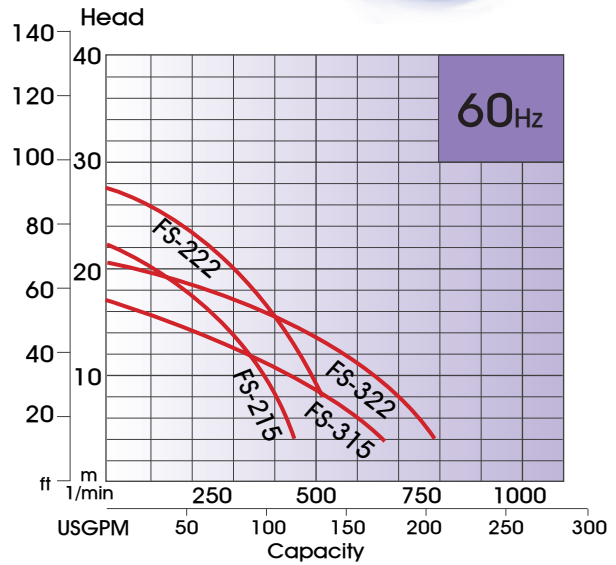
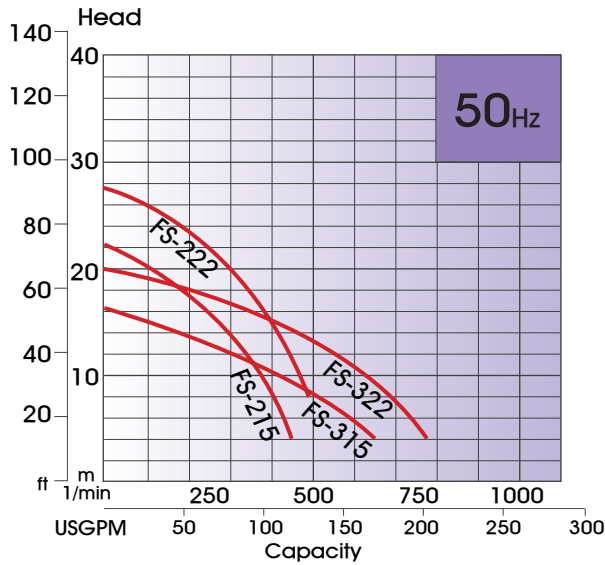

Technical Specifications

Type	Outlet		Output		Voltage 3 phase	Nor.Head		Nor.Capa.		Max.Head		Max.Capa.		Solid Pass.		Weight	
	mm	inch	Kw	hp		m	ft	l/min	USgpm	m	ft	l/min	USgpm	mm	inch	kg	lb
FS-215	50	2	1.5	2	220v	15	50	250	66	22	72	450	119	9	0.36	34	75
FS-315	80	3	1.5	2	380v	8	26	500	132	16	53	650	172	9	0.36	34	75
FS-222	50	2	2.2	3	415v	20	66	300	79	27	89	500	132	9	0.36	36	79
FS-322	80	3	2.2	3	440v	10	33	600	159	20	33	800	211	9	0.36	36	79

*1 phase is available for 1.5kw (2HP) pump — FS - 215S & 315S

Dimensions & main parts description

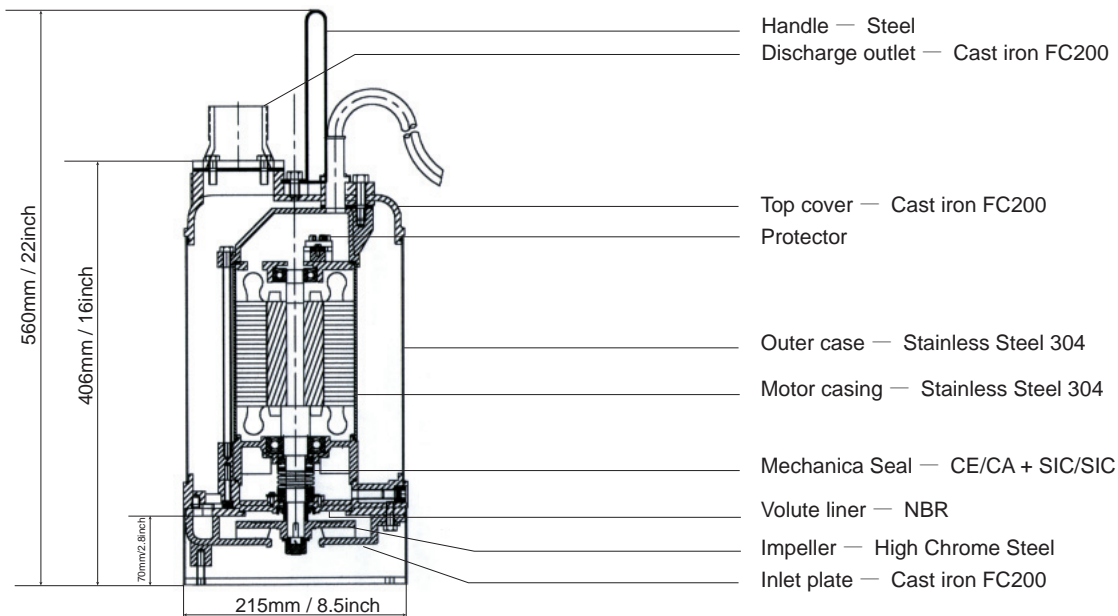

Discharge: 50mm (2") or 80mm (3"), and 100mm (4")

Power Output: 3.7kw (5hp) and 5.5kw (7.5hp)

Head: up to 36m (120ft)

Flow: up to 1700 l/min (450 USgpm)



Performance Curve

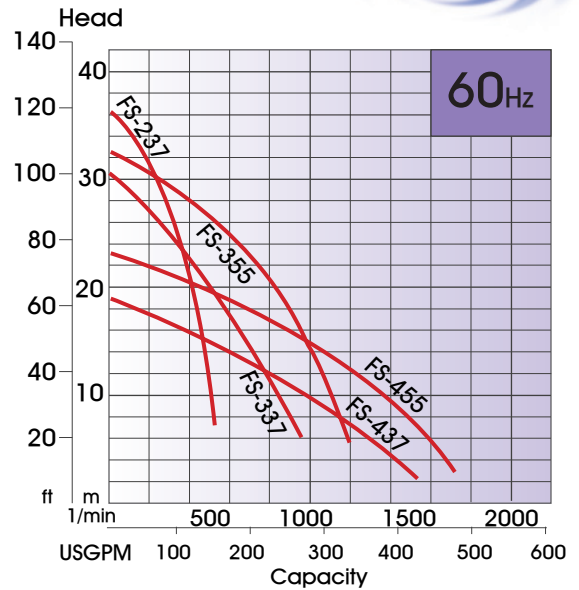
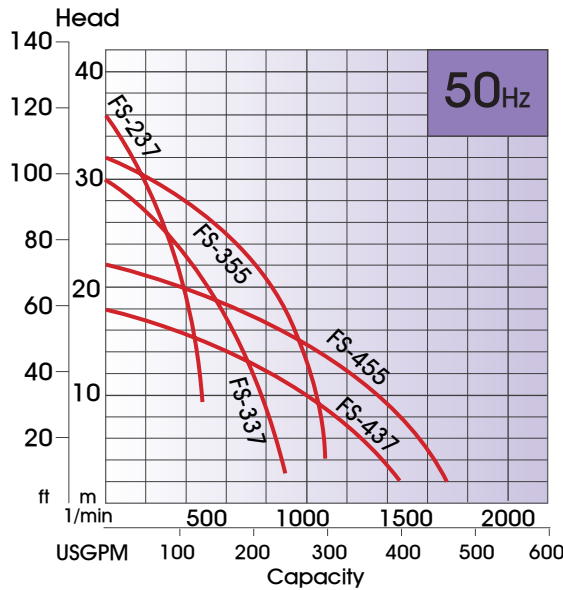

Technical Specifications

Type	Outlet		Output		Voltage 3 phase	Nor.Head		Nor.Capa.		Max.Head		Max.Capa.		Solid Pass.		Weight	
	mm	inch	Kw	hp		m	ft	l/min	USgpm	m	ft	l/min	USgpm	mm	inch	kg	lb
FS-237	50	2	3.7	5	220v	30	99	200	53	36	118	500	132	11	0.4	45	99
FS-337	80	3	3.7	5	380v	20	66	500	132	30	99	900	238	11	0.4	45	99
FS-437	100	4	3.7	5	415v	10	33	1000	264	18	59	1500	396	11	0.4	45	99
FS-355	80	3	5.5	7.5	440v	25	82	600	159	32	105	1200	317	11	0.4	50	110
FS-455	100	4	5.5	7.5		15	49	1000	264	22	72	1700	449	11	0.4	50	110

Dimensions & main parts description

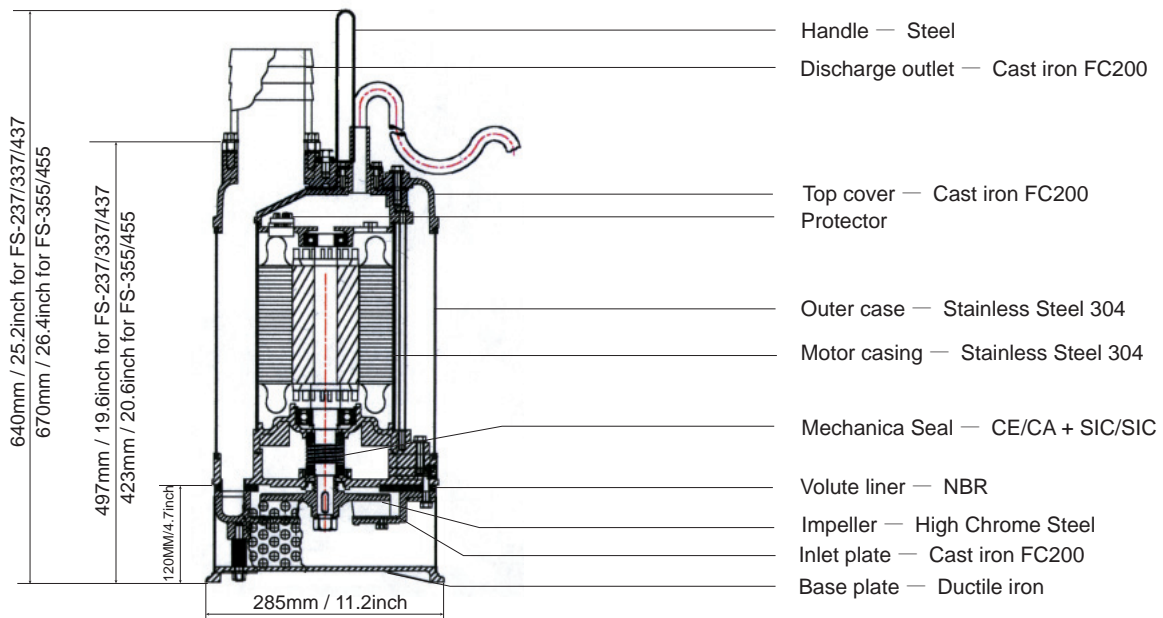

Discharge: 100mm (4") or 150mm (6")
Power Output: 7.5kw (10hp) and 11kw (15hp)
Head: up to 51m (163ft)
Flow: up to 2500 l/min (660 USgpm)



Performance Curve

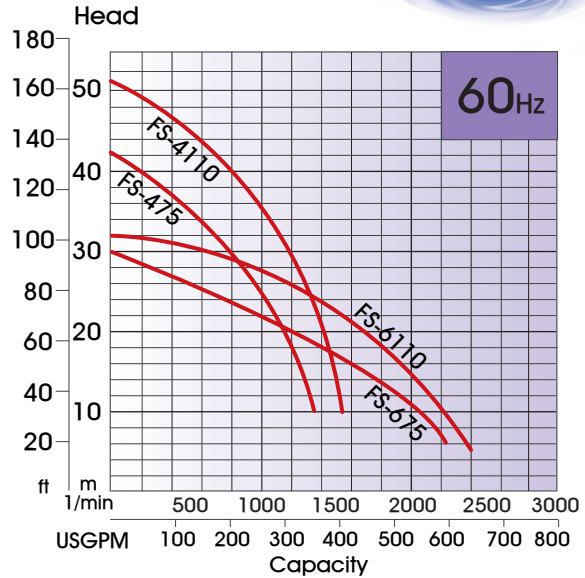
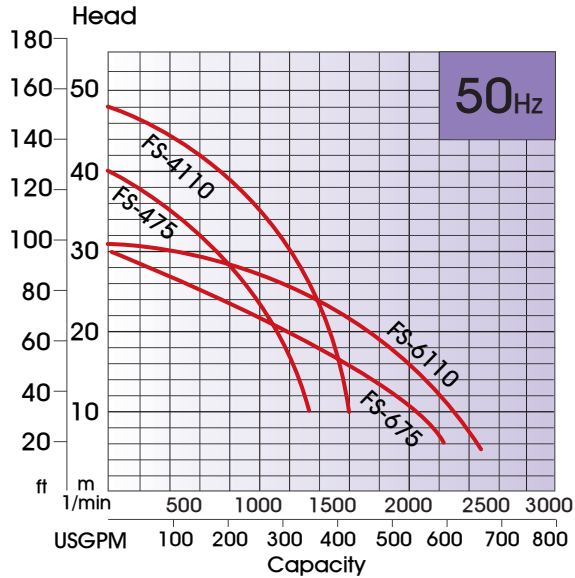

Technical Specifications

Type	Outlet		Output		Voltage 3 phase	Nor.Head		Nor.Capa.		Max.Head		Max.Capa		Solid Pass.		Weight	
	mm	inch	Kw	hp		m	ft	l/min	USgpm	m	ft	l/min	USgpm	mm	inch	kg	lb
FS-475	100	4	7.5	10	380V	30	99	800	211	42	139	1600	423	15	0.6	86	189
FS-675	150	6	7.5	10	415V	15	50	1600	423	31	102	2200	581	15	0.6	86	189
FS-4110	100	4	11	15	440V	35	120	1000	264	51	163	1700	449	15	0.6	93	205
FS-6110	150	6	11	15	440V	20	66	1700	449	32	105	2500	660	15	0.6	93	205

Dimensions & main parts description

